

Features

- Peak equivalent, true RMS or true peak output
- Temperature signal output
- Optional dynamic signal output
- Corrosion resistant
- Hermetic seal
- ESD protection
- Overload protection
- Reverse wiring protection

Benefits

- Choice of output: RMS, equivalent peak, and true peak; permits you to choose the sensor that best fits your industrial requirements
- Provides continuous trending of overall machine vibration
- Can help guide maintenance

The 4-20 mA output of the PC427 Series is proportional to vibration. An output of 4 mA indicates a level of 0 ips or no vibration present for velocity output models and 0 g for acceleration output models. A full-scale reading of 20 mA indicates that the maximum range (RMS, equivalent peak or true peak) of vibration is present.

The dynamic signal output is an optional addition. Any of the base sensor models can also have dynamic signal output. Adding -DA to a model specifies a dynamic acceleration signal output (100 mV/g). Adding -DV to a model specifies a dynamic velocity signal output (100 mV/ips).

The temperature output of the PC427 Series is in terms of degrees kelvin (°K), where zero °K = -273°C. The voltage output at 0°C = 2.73 volts (273°K). The voltage output at 80°C = 3.53 volts (353°K).

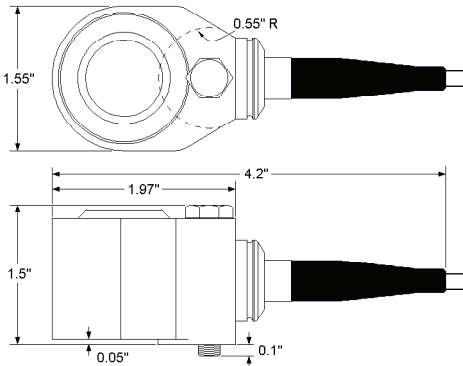

Model PC427 Series Side exit, 4-20mA, integral cable Vibration and temperature voltage (LPS™)

Output, 4-20 mA

Full scale, 20 mA (±5%)	see table 1 on back
Frequency response:	
±10%	10 Hz - 1.0 kHz
±3 dB	4 Hz - 2 kHz
Repeatability	±2%
Transverse sensitivity, max.....	5%

Output temperature

Temperature output sensitivity, ±5°K.....	10 mV/°K
Temperature measurement range.....	223 to 358°K (-50 to 85°C)

Output, dynamic (optional)

	PC427xxx-yy-DA	PC427xxx-yy-DV
Sensitivity (±10%)	100 mV/g	100 mV/ ips
Full scale	20g, peak	1.5 ips @ 1kHz
Frequency response:		
±3 dB	2.5 Hz - 10 kHz	2.5 Hz - 2.5 kHz
Amplitude nonlinearity, maximum	1%	
Resonant frequency, mounted, nominal	21 kHz	
Transverse sensitivity, max.	5%	

Electrical

Power requirements (two wire loop power):

Voltage (between black and red wire)	10 VDC min, 30 VDC max
Loop resistance ¹ at 24 VDC, maximum.....	700Ω
Turn on time, 4-20 mA loop	30 seconds
Grounding.....	case isolated, internally shielded

Power requirements (two wire loop power):

Current.....	0.4 to 5 mA
--------------	-------------

Environmental

Temperature range	-40 to 85°C
Vibration limit	250 g peak
Shock limit	2,500 g peak
Sealing	hermetic

Physical

Sensing element design	PZT ceramic / shear
Weight	320 grams
Case material	316L stainless steel
Mounting	1/4 - 28 captive bolt
Cabling	J95

Cable wire	Function
Shield	ground
Red	loop positive (+)
Black	loop negative (-)
White	dynamic signal (optional)
Yellow	temperature signal
Green	temperature common

See back for notes.

Wilcoxon Research Inc
21 Firstfield Rd
Gaithersburg, MD 20878
USA

Tel: 301 330 8811
Fax: 301 330 8873

Email: sensors@wilcoxon.com

www.meggitt.com

Notes: ¹ maximum loop resistance (RL) can be calculated by:

$$RL \text{ (max. resistance)} = \frac{V_{DC \text{ power}} - 10 \text{ V}}{20 \text{ mA}}$$

DC Supply Voltage	R _L (max resistance) ²	R _L (minimum wattage capability) ³
12 VDC	100Ω	1/8 Watt
20 VDC	500Ω	1/4 Watt
24 VDC	700Ω	1/2 Watt
26 VDC	800Ω	1/2 Watt
30 VDC	1.0kΩ	1/2 Watt

² Lower resistance is allowed, greater than 10Ω recommended

³ Minimum R_L wattage determined by: (0.0004 x R_L)

⁴ The temperature sensor must have a current flow to operate. This current can be provided through constant-current diodes (i.e. Vishay J508, etc.)

Table 1: PC427xxx-yy-Dz Model number selection

xxx (4-20 mA output type)	-yy (full scale)	-Dz (dynamic output) ^A
AR = acceleration, RMS AP = acceleration, equivalent peak ^B ATP = acceleration, true peak ^C	-05 = 5 g (49 m/sec ²) -10 = 10 g (98 m/sec ²) -20 = 20 g (196 m/sec ²)	-DA = dynamic acceleration 100 mV/g (10.2 mV/ m/sec ²) -DV = dynamic velocity 100 mV/ips (3.94 mV/ mm/sec)
VR = velocity, RMS VP = velocity, equivalent peak ^B VTP = velocity, true peak ^C	-05 = 0.5 i.p.s. (12.8 mm/sec) -10 = 1.0 i.p.s. (25.4 mm/sec) -20 = 2.0 i.p.s. (50.8 mm/sec) -30 = 3.0 i.p.s. (76.2 mm/sec) -50 = 5.0 i.p.s. (127 mm/sec)	-DA = dynamic acceleration 100 mV/g (10.2 mV/ m/sec ²) -DV = dynamic velocity 100 mV/ips (3.94 mV/ mm/sec)

^A **Dynamic output is an option on all models.** If dynamic output option is not desired, do not add -DA or -DV to the model number.

^B **Equivalent peak output is developed based on the true RMS value of vibration.** For a pure sine wave, the equivalent peak output is 1.414 times the RMS value.

^C **True peak output is based on the actual measured peak value using the time waveform and is not based on the RMS calculation.**

PC427xxx-yy wiring

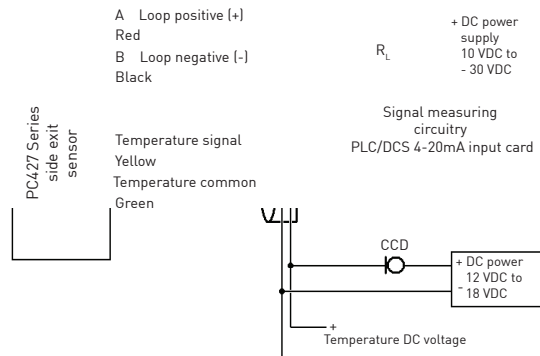

PC427xxx-yy-Dz wiring

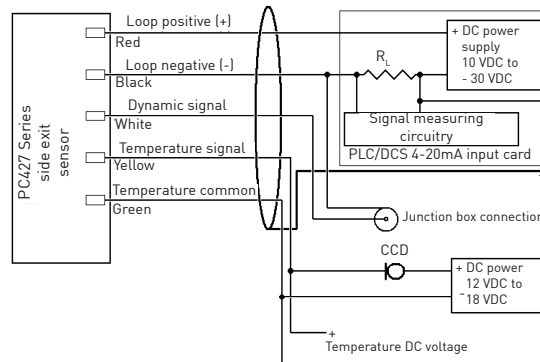

All wire and cable used for installation of the PC425 Series sensor should be shielded. Generally accepted instrumentation wiring practice considers the best way to ground the shield is to connect it at only one end of the cable. The shield should not be wired to ground at both ends of the cable. The Wilcoxon PC427 Series sensor has the shield connected to the case at the sensor end of the cable.